

# HDL 6-A

## ACTIVE LINE ARRAY MODULE



### DESCRIPTION

The HDL6-A is the ideal choice when line array performance is needed and a fast and easy set-up a must. A 1400 W 2-channel class-D amplifier powers the system.

A powerful DSP processes the sound including crossover, phase correction, limiting and protection. The system features state-of-the-art RCF transducers – two powerful 6.0" woofers for a solid bass reproduction plus a high powered 1.7" voice coil compression driver mounted on a precise 100° x 10° waveguide delivers vocal clarity with high definition and an incredible dynamic.

### MAIN APPLICATIONS

- Live sound
- Rental
- Portable PA, clubs, ballrooms, live theatre
- House of worship
- Theme parks
- Music playback and sound reinforcement in small and mid-size venues
- Corporate A/V professionals and sound system hire companies

### MAIN FEATURES

- 1400 W, two-way amplification
- 131 dB max SPL
- 1.7" voice coil neodymium compression driver
- 2 x high power neodymium 6.0" woofers
- 48 kHz, 32 bit floating point DSP processing
- Symmetrical design
- Extremely low weight
- FIRPHASE processing

### ACOUSTICAL SPECIFICATIONS

Frequency response:	65 Hz ÷ 20000 Hz
Max SPL:	131 dB
Horizontal coverage angle:	100°
Vertical coverage angle:	10°
Compression driver:	1.0" neo, 1.75" v.c
Woofers:	2 x 6.0" neo, 2.0" v.c

### INPUT/OUTPUT SECTION

Input signal:	bal/unbal
Input/Output connector:	XLR
Input sensitivity:	+ 4 dBu

### PROCESSOR SECTION

Crossover frequencies:	900 Hz
Protections:	thermal, rms
Limiter:	soft limiter
Controls:	HF correction

### AMPLIFIER

Total Power:	1400 W Peak, 700 W RMS
High frequencies:	400 W Peak, 200 W RMS
Low frequencies:	1000 W Peak, 500 W RMS
Cooling:	convection
Connection:	Powercon IN/OUT

### PHYSICAL

Height:	237 mm / 9.33 inches
Width:	470 mm / 18.5 inches
Depth:	377 mm / 14.84 inches
Weight:	11.6 kg / 25.57 lbs
Cabinet:	PP Composite
Hardware:	Array fittings
Handles:	2 back
Colour:	Black



# HDL 6-A

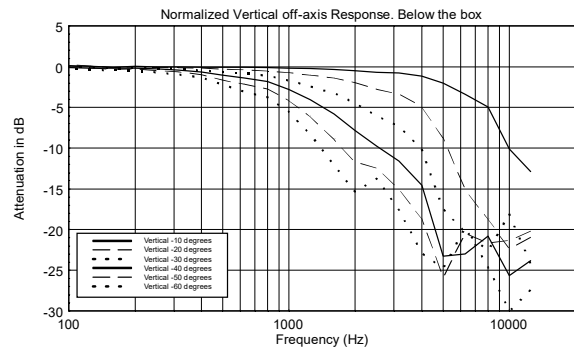
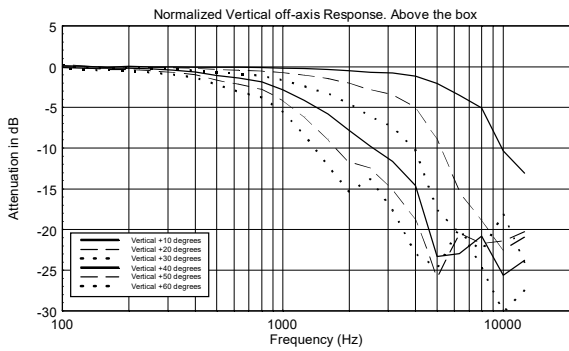
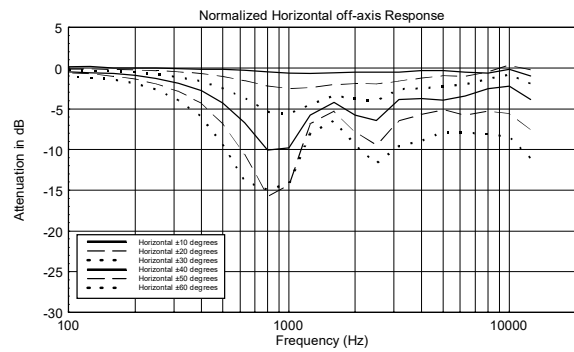
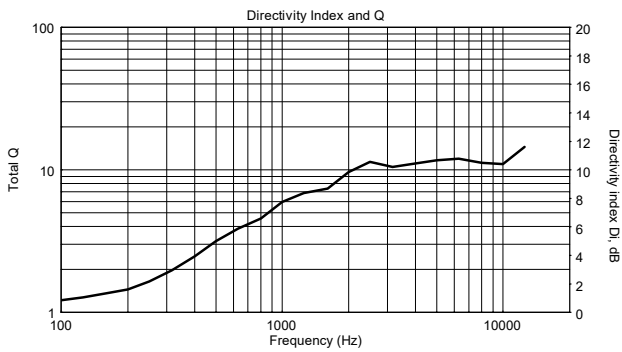
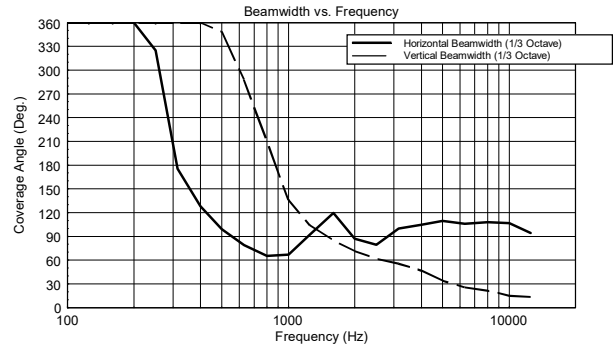
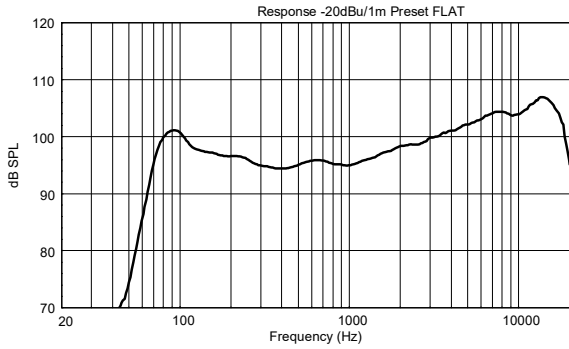

# HDL 6-A

Horizontal 1/3 Octave Polars

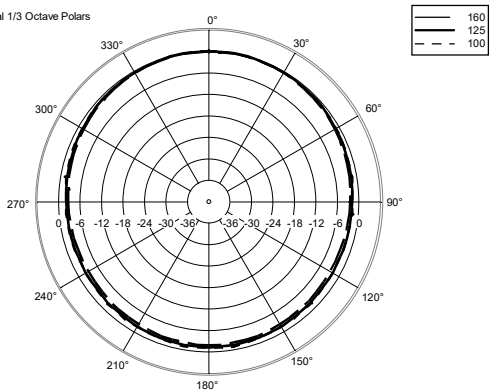

Horizontal 1/3 Octave Polars

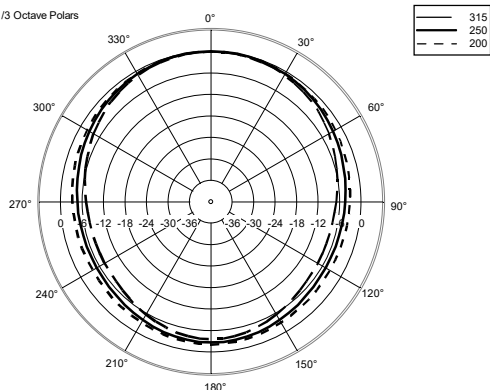

Horizontal 1/3 Octave Polars

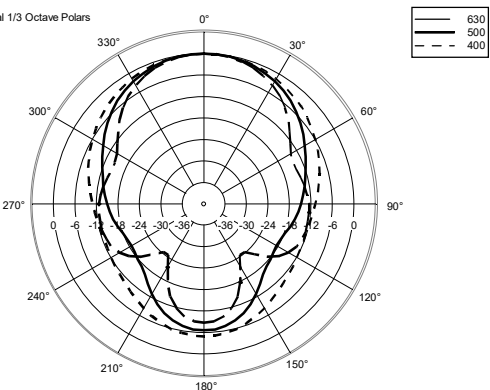

Horizontal 1/3 Octave Polars

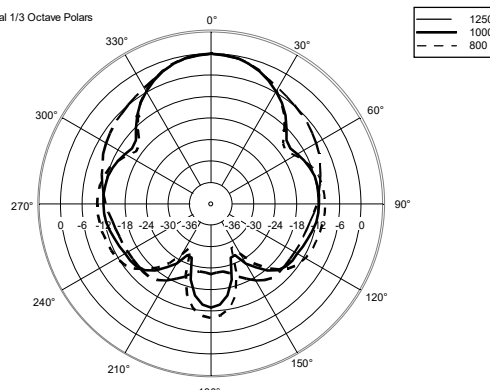

Horizontal 1/3 Octave Polars

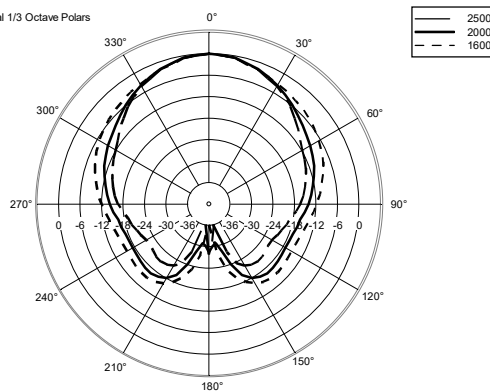

Horizontal 1/3 Octave Polars

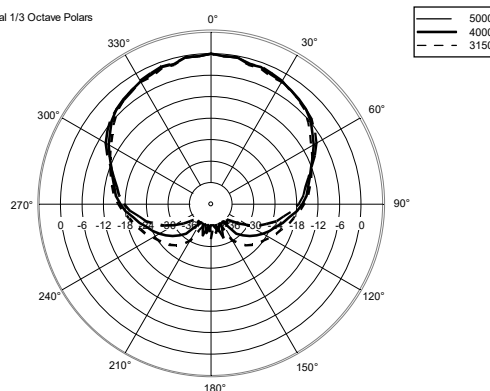

Horizontal 1/3 Octave Polars

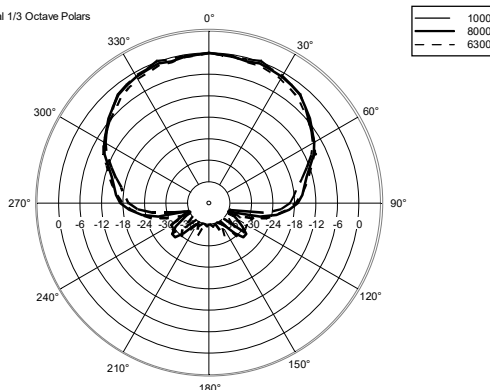

Horizontal One Octave Polars

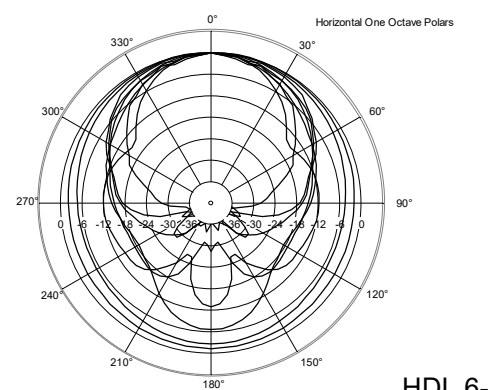

HDL 6-A



# HDL 6-A

## PART NUMBER

13000496 (230 V)  
13000509 (115 V)

## DIMENSIONS (All data are in mm)

